

Extending the Offset Frequency Range of the D2-135 Offset Phase Lock Servo by “Indirect” Locking

Introduction

The Vescent Photonics [D2-135 Offset Phase Lock Servo](#) is normally used to phase lock a pair of lasers with a user-adjustable frequency offset between 250 MHz and ≥ 9.5 GHz. It features a full PID loop filter transfer function with adjustable poles and gain with bandwidth from DC to 10 MHz. Because it employs a phase-frequency detector a true phase lock with the capture range of a frequency lock is possible. It features a feed forward input that allows for frequency jumps of the slave laser in as little as 35 μ s. It has an on-board VCO to provide the offset reference frequency or will accept an external frequency reference. The lock range is normally sufficient for many applications including cooling of atomic Cesium which requires an offset on the order of 9.2 GHz.¹ But some work requires the two lasers to be locked with larger offsets than this. In this application note we demonstrate a method for achieving offsets of at least 43 GHz with indications that with the proper equipment the offset could be extended to 100 GHz or more.

Principle

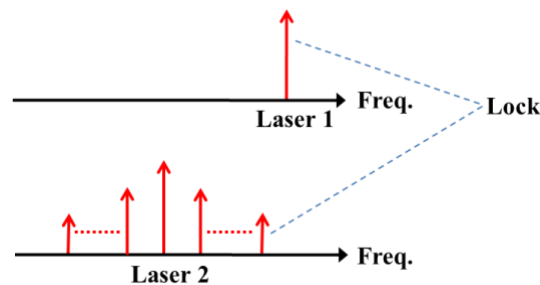

Figure 1. Principle of the “indirect” locking.

The concept of extending the offset frequency using the D2-135 OPLS is shown in Figure 1. In this scheme, laser 1 is not locked to laser 2 directly. Instead, laser 2 is first modulated to add sidebands, and then laser 1 is locked to a sideband of laser 2. Since the modulated sidebands are locked to the carrier automatically, laser 1 will be locked with the laser 2 carrier. Therefore, it can be called “sideband” or “indirect” locking of two lasers.²

Experimental setup

¹ <http://steck.us/alkalidata/cesiumnumbers.1.6.pdf>

² V. Ferrero and S. Camatel, “Optical phase locking techniques: an overview and a novel method based on single side sub-carrier modulation,” [Opt. Express, 16, 818-828 \(2008\)](#).

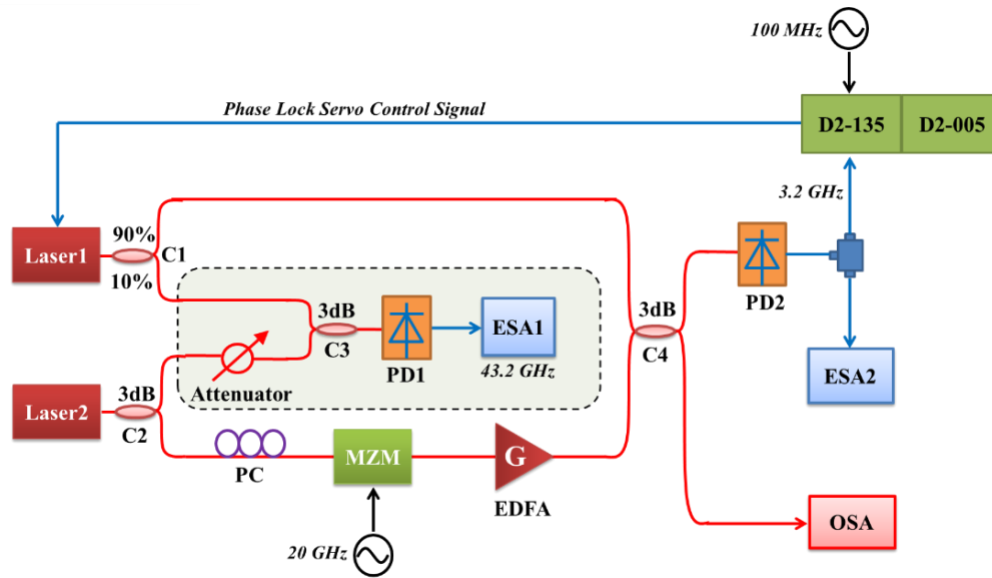

Figure 2. Schematic of the proposed scheme (PD: photo-detector, ESA: electrical spectrum analyzer, PC: polarization controller, MZM: Mach–Zehnder modulator, EDFA: erbium-doped fiber amplifier, OSA: optical spectrum analyzer).

The experimental setup is shown in Figure 2. Two Orbits Lightwave lasers³ with a frequency spacing of about 43.2 GHz are used: laser 1 is used as the slave laser and its frequency can be tuned by a PZT inside the laser; laser 2 is used as the master laser and its frequency is fixed. To monitor the beat signal of the two lasers, two optical couplers (C1, C2) are used after the lasers and part of their light is sent to another 3 dB coupler C3. After detection by a photo-detector (PD1, Newport D-15ir), the electrical beat signal is sent to an electrical spectrum analyzer (ESA1, R&S FSU). In the other arm of coupler C2, part of the light from laser 2 is sent to a Thor Labs polarization controller (PC), and then is modulated by an intensity modulator (Eospace) that is driven by an RF source (Agilent E8257D). The modulated signal is amplified to 23 dBm by an EDFA (Keopsys) to increase the intensity of the higher-order sidebands and then combined with light from Laser 1 by a 3 dB optical coupler, C4. An optical spectrum analyzer (HP 70951A) is used after the coupler C4 to monitor these two optical signals. The beat signal is detected by a home-built photo-detector (PD2) and then split in two: one half is sent to an electrical spectrum analyzer (Agilent E4440A); the other one is sent to the Vescent Photonics D2-135 offset phase lock servo as the error signal. The D2-135 OPLS is used with its frequency divider set to “N=32” (the electrical beat note is divided by 32 before comparison with the reference frequency) and therefore an external reference signal of 100 MHz is used. Because the beat note is divided by 32, the 100 MHz reference signal corresponds to an offset of 3.2 GHz. This reference signal is provided by another RF source (Agilent E8257D). The error signal is processed by the D2-135 PID loop filter and an appropriate servo signal from the OPLS is sent to laser 1 to adjust its wavelength.

³ http://www.orbitlightwave.com/assets/pdf/Etherna_SlowLight_Lasers.pdf

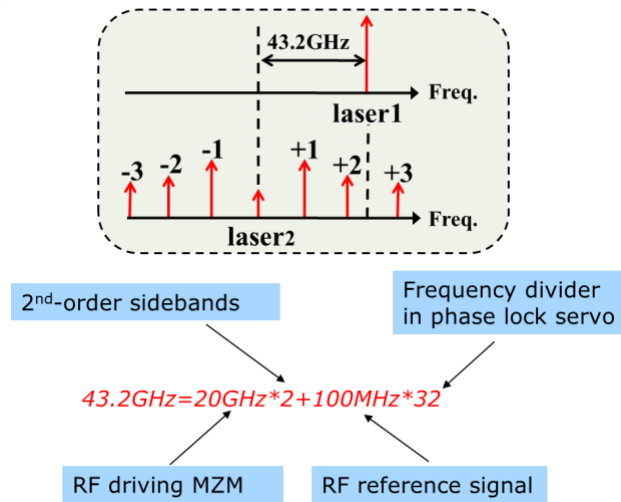

Figure 3. Principle of locking two lasers with a frequency difference of 43.2 GHz.

The principle of the experiment is shown in Figure 3. The frequency difference between the carrier of laser 2 and laser 1 is set to 43.2 GHz. To maximize the sidebands of the modulated signal, the light from laser 2 is carrier-suppressed modulated at 20 GHz. Since the frequency spacing of these sidebands is 20 GHz, the frequency difference between the +2nd-order sideband and laser 1 is 3.2 GHz. The beat signal at 3.2 GHz is sent to the D2-135 OPLS. The higher frequency beat notes between laser 1 and the carrier of laser 2 (43.2 GHz) or the +1st-order sideband of laser 2 (23.2 GHz) are filtered by the response of the cabling and the OPLS itself, so no additional filtering was necessary to remove them. In this way, a phase lock of laser 1 and laser 2 is realized by locking laser 1 and the +2nd-order sideband of laser 2. The equation in

Figure 3 shows the principle mathematically. By extension, if laser 1 were to be locked to a higher-order sideband of laser 2, the offset frequency could be further increased.

Results and discussions

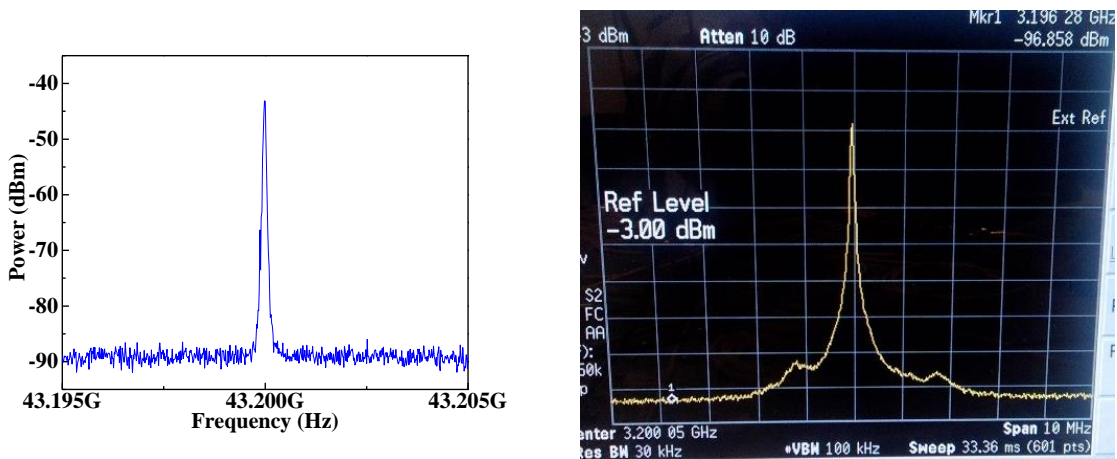

Figure 4. Averaged electrical beat signal at ESA1 and ESA2 with phase lock. Span: 10 MHz.

The electrical spectrum of the beat signal at ESA1 and ESA2 after phase locking is shown in Figure 4. The span is 10 MHz and the central frequency is 43.2 GHz and 3.2 GHz respectively.

Without phase locking, it is very difficult to capture the spectrum of the beat signals in a span of 10 MHz because of the fast frequency drift of the two lasers. Due to the phase noise of the RF signal that is used to drive the modulator, the signal quality of the beat signal at ESA1 is not as good as that at ESA2.

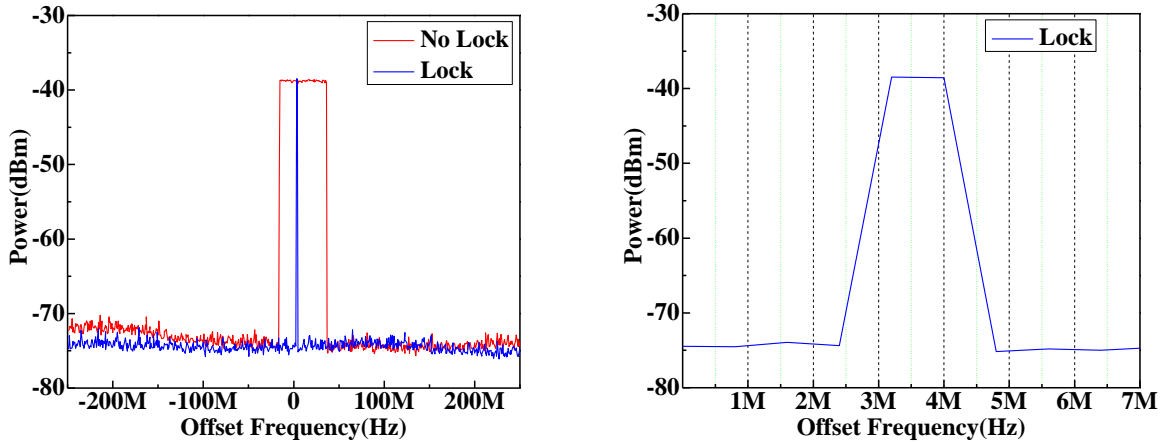

Figure 5. left: Comparison of the frequency drift range (span: 500 MHz). Note in the left panel, the x-axis is offset frequency with respect to 43.2 GHz. The right panel is a zoom in of the locked beat (span: 7 MHz). Measurements made over a 2-minute period. RBW = 100 kHz and VBW = 300 kHz for both panels.

Figure 5 shows a comparison of the beat signal (measured by ESA1) before and after phase locking. Using the “Max Hold” function of the electrical spectrum analyzer, we can clearly see the frequency drift range of the electrical beat signal. In the experiment, we use “Max Hold” function for two minutes. When there is no lock, the frequency drift range in 2 minutes is about 55 MHz, while there is <1 MHz frequency drift after phase locking over the same time period. (This 1 MHz measurement is an upper limit most likely limited by the large Resolution Bandwidth set automatically by the spectrum analyzer. See discussion regarding Figure 6 below.)

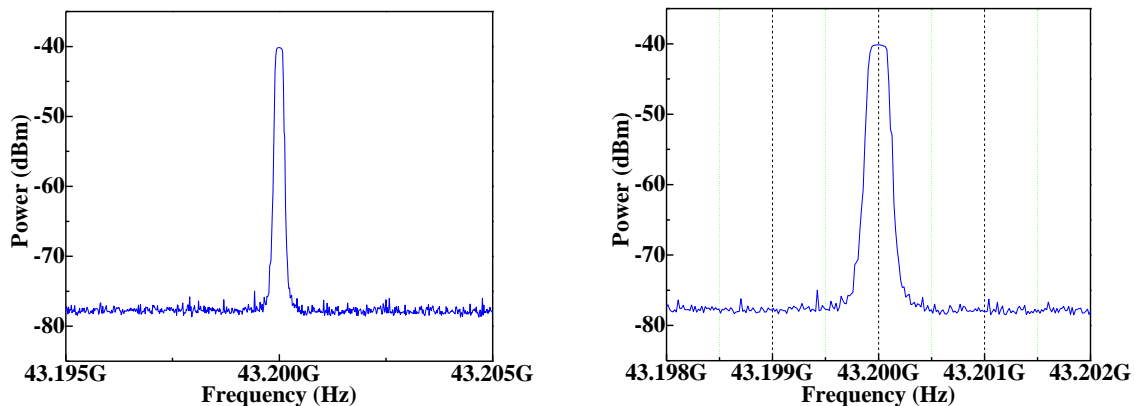

Figure 6. Frequency drift of the beat signal in 20 minutes with phase lock. Span: 10 MHz (left) and 4 MHz (right). RBW = 30 kHz and VBW = 100 kHz for both panels.

To measure the long-term stability of this scheme after phase locking, we let the system run for 20 minutes. As mentioned above, we can use the “Max Hold” function to measure the frequency drift range. In Figure 6, there is about 200 kHz frequency drift during 20 minutes. Presumably, the decrease in measured drift in going from the 2-minute integration of Figure 5 to the 20-minute integration of Figure 6 is the result of the ESA auto-switching the RBW to a lower value. However, this work did not confirm this.

In this scheme, the linewidth of the slave laser and master laser have a significant influence on the stability of the beat signal after locking. If the frequency of one laser is very unstable, it is very difficult to lock these two lasers due to the limited control range of the D2-135 phase lock servo. In addition, the offset frequency of these two lasers is limited by the power of the beat signal between laser 1 and sidebands of laser 2. If a power amplifier is used to amplify the RF driving signal of the MZM, more sidebands will be generated and laser 1 can be locked to higher-order sidebands of laser 2. For example, if the power of 20 GHz driving signal were to be large enough to generate 5th-order sidebands, laser 1 could be locked with +5th-order sideband of laser 2 and an offset frequency of more than 100 GHz could be realized.